

300V 20A 20-10AWG 4.0mm²

Poles: 1P/2P

Pitch: 7.5mm (.295")

Materials

Housing: PA66 (UL 94V-0)

Contact: Brass, Tin Plated

Wire Cage: Brass, Nickel Plated

Screw: M3.5, Steel, Cr3+ Zinc Plated

Torque: 0.8N.m

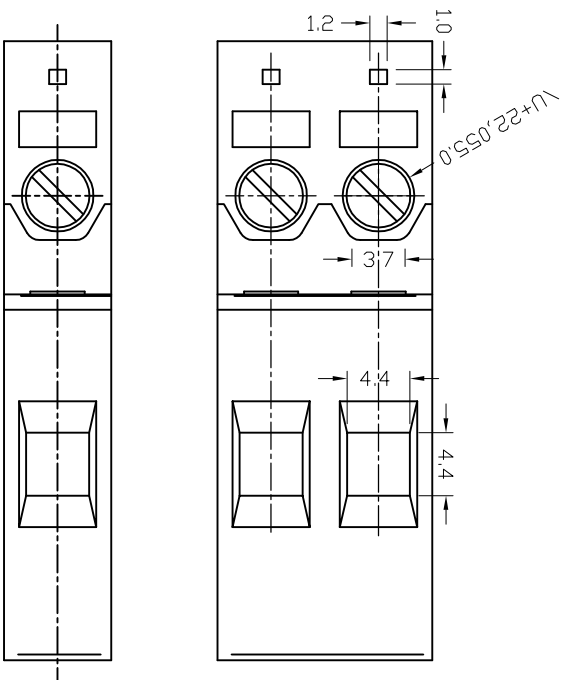

设计/Drawn by

绘图/Drawn by

审核/Checked by

批准/Approved by

未注公差
General Tolerance

图名/Title

文件编号/File No.

XY260 产品图

页序/Sheet

单位/Units: mm

序号/Rev.No.

更改记录/Revision note

签名/Signature

日期/Date



XINLANYA ELECTRONIC CO., LTD

备注/Remark