

TO: \_\_\_\_\_

DATE: \_\_\_\_\_

# 引线型锂离子电容器产品规格书

## RADIAL-TYPE LITHIUM ION CAPACITOR SPECIFICATION

型号 MODEL: LIC 1340 H 4R2 C550

合盛新能（宁波）科技有限公司

HESHENG ALTERNATIVE ENERGY TECHNOLOGY CO., LTD.

[www.btcap.net](http://www.btcap.net)

TEL: 0574-87906826

E-MAIL: heshengxinneng@btcap.net

## 目录 CONTENTS

1. 概述 Introduction.....	4
2. 产品通用特性 General Features.....	4
2.1 特点与优势 Features and Advantages .....	4
2.2 典型应用领域 Typical Applications.....	4
3. 产品外观和尺寸 Product Appearance & Dimensions.....	4
3.1 结构及外观 Structure & Appearance .....	4
3.2 尺寸 Dimension (单位: mm) .....	5
4. 产品技术指标 Product Technical Index .....	5
4.1 主要参数 Main Parameters .....	5
5. 性能特性 Technical Information .....	6
6. 其它信息 Other Technical Information .....	7
7. 产品测试方法 Testing Methods.....	8
7.1 测试条件 Testing Conditions.....	8
7.2 测量工具要求 Testing Demands for Tools .....	8
7.3 容量测试 Test for Capacitance .....	9
7.4 交流内阻测试 Test for AC Resistance.....	10
7.5 高低温性能测试 Test for Low-high Temperature .....	10
7.6 高温高湿存储特性 High temperature and high humidity storage properties .....	11
7.7 充/放电循环性能测试 Charge/discharge cycling properties .....	11
8. 注意事项 Notice.....	11
8.1 使用 During Operation.....	11

8.2 储存 Storage.....	13
8.3 包装 Packaging.....	14

## 1. 概述 Introduction

本产品规格书对宁波瞬能科技有限公司开发的引线型锂离子电容器产品LIC 1330 H 4R2 C550的性能、测试方法及注意事项等进行了说明。

This specification describes the properties, testing methods and notice of the Radial-Type Lithium ion capacitor ( LIC 1330 H 4R2 C550) developed by NINGBO BURSTCAP TECHNOLOGY CO., LTD.

## 2. 产品通用特性 General Features

### 2.1 特点与优势 Features and Advantages

- ❖ 低自放电 Low Self Discharge
- ❖ 高容量(同体积EDLC20倍) High Capacitance(Near 10 time of EDLC)
- ❖ 高工作电压(4.2V) High operating Voltage(4.2V)
- ❖ 绿色环保 Green and Environmental
- ❖ 免维护 Maintenance-Free

### 2.2 典型应用领域 Typical Applications

- ❖ 3.67V一次锂电池市场: 水表、气表、电表等 With 3.67V Li-primary Battery: Water meter, Gas meter, Electric meter and et al.
- ❖ GPS跟踪/RF和通信电源 GPS tracking, RF and Communication power supply
- ❖ NB通信/脉冲功率电源 NB IOT/Pulse power supply
- ❖ 电动工具/ETC及其它快充电源 Electric Tool/ETC/Quick Charge power
- ❖ 电子烟市场 Electronic cigarettes.

## 3. 产品外观和尺寸 Product Appearance & Dimensions

### 3.1 结构及外观 Structure & Appearance

本产品为引线型单体, 基于双电层电容器+锂离子电池内部“并联”的新型储能器件, 两极间用隔膜隔开, 电解液填充于单元内部空间, 用橡胶塞对铝外壳进行密封, 两极的引线端子位于产品顶端。

This product is a radial cell with the parallel of electric double-layer capacitor + lithium ion battery. It consists two electrodes, an insulation separator and electrolyte filled in the cell. Rubber stoppers are used to seal the aluminum case, with two radial located on the top.



### 3.2 尺寸 Dimension (单位: mm)

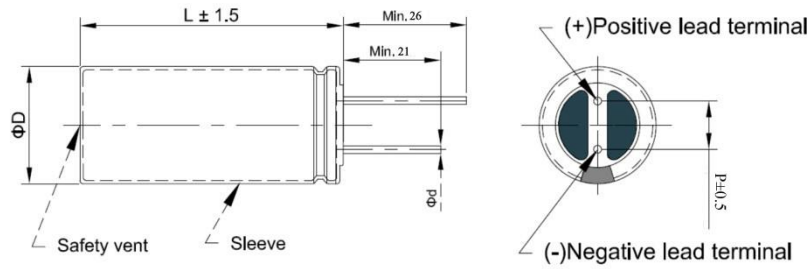

型号系列 Series	ΦD (mm)	L (mm)	Φd (mm)	P (mm)	重量 (g)
LIC 1340 H 4R2 C550	12.5 + 1.5 Max	40±1.5	Φ0.6±0.1	5.0±0.5	≤8.0

## 4. 产品技术指标 Product Technical Index

### 4.1 主要参数 Main Parameters

序号 Series	特性 Merits	LIC 1340H
4.1	工作温度 Working Temperature	-40°C~65°C
4.2	工作电压 Work Voltage	2.5~4.2V
4.3	最低电压 Mix Voltage	2.5V
4.4	额定容量(@25±2°C) Standard Capacitance	550F/280mAh
	电容公差 Tolerance	-20%~+80%
4.5	内阻 AC (1kHz, 4.2V) AC Resistance	≤50mΩ
4.6	内阻 DC (1s@1C@25±2°C) DC Resistance	≤80mΩ
4.7	最大放电 连续放电 Continuous	4.0A

	电流 Max. discharge current	脉冲 Pulse (1sec).	28.0 A
4.8	最大充电电压/电流 Max charge voltage/current		4.2V 3.0A
4.9	标准重量 (g) Mass		≤8.0
4.10	最佳存储环境 Optimum storage condition		+10°C~55°C 60%RH 或以下

## 5. 性能特性 Technical Information

序号	项目 Items	性能 Properties	测试方法 Testing Method
5.1	高低温特性 High-low Temp. properties	电容(-40°C): 初始测量值的±50% 内阻(-40°C): ≤初始规定值的 20 倍 电容(+65°C): 初始测量值的±30% 内阻(+65°C): ≤初始规定值的 2 倍	见 7.5
5.2	高温高湿存储特性 High temp. and high humidity storage properties	电容: 初始测量值的±30% 内阻: ≤初始规定值的 2 倍	见 7.6
5.3	充电/放电循环特性 Charge/discharge cycling properties	电容: 初始测量值的±30% 内阻: ≤初始规定值的 4 倍	见 7.7

<b>5.4</b>	外观	没有明显的渗漏, 变形, 污点, 伤痕,
	Appearance	锈蚀和毛刺。

## 6. 其它信息 Other Technical Information

### ❖ 倍率放电容量变化 Capacitance changes at different discharge rate

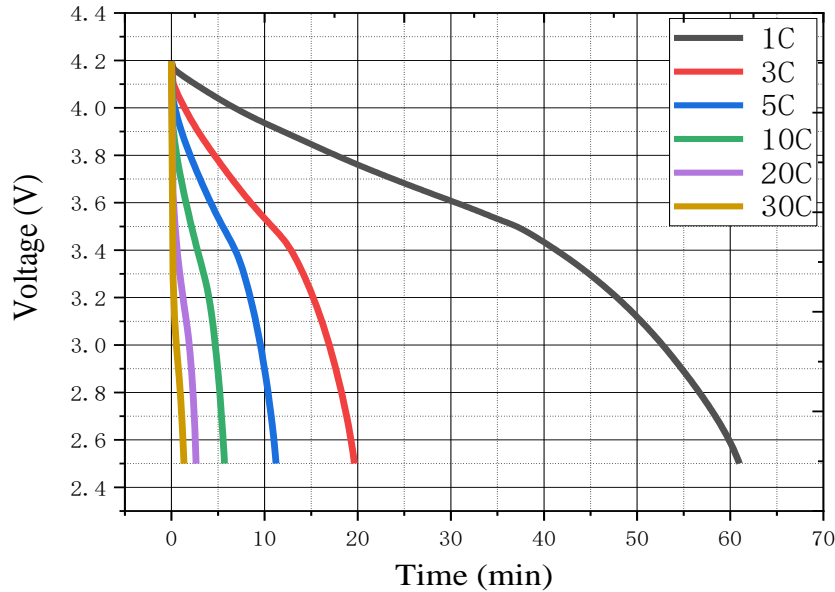

### ❖ 低温放电容量变化 Capacitance changes at low temp. discharge condition

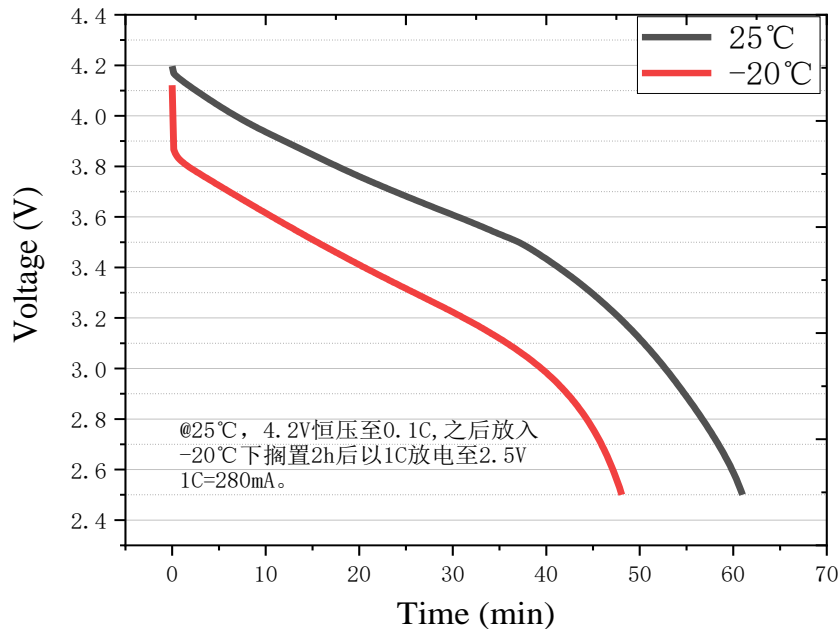

### ❖ 自放电电压变化 Voltage changes at different self-discharge condition

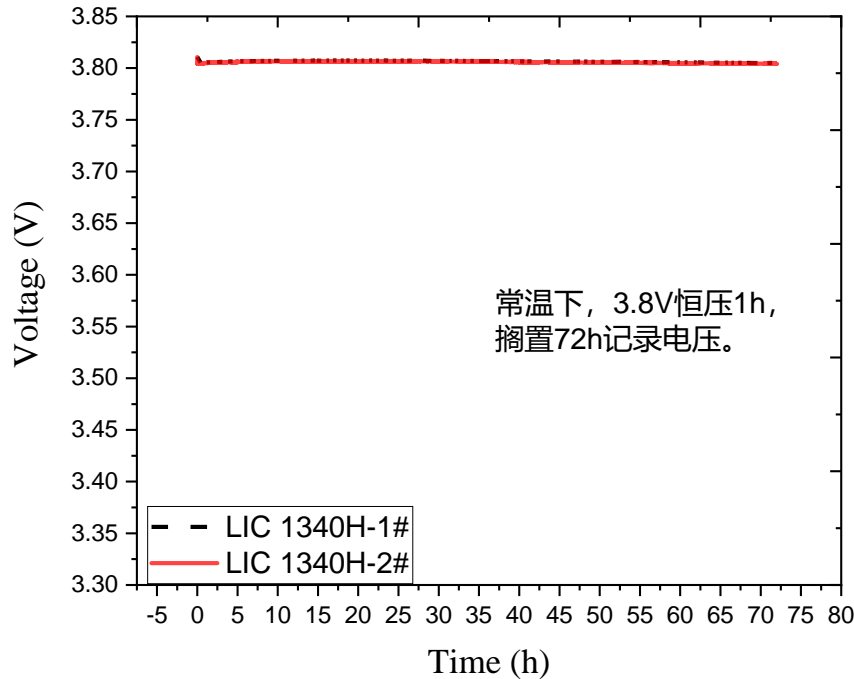

## 7. 产品测试方法 Testing Methods

### 7.1 测试条件 Testing Conditions

本产品规格书标准测试条件为：标准大气压下，温度 $25\pm 2^{\circ}\text{C}$ ，相对湿度小于65%。

This specification followed the standard testing criteria: 1 atm,  $25\pm 2^{\circ}\text{C}$  and a relative humidity < 65%.

### 7.2 测量工具要求 Testing Demands for Tools

❖ **尺寸**：必须使用 JIS B 7503 / KS B 5206(千分尺), JIS B 7507 / KS B 5203-2(游标卡尺) JIS B 7502 / KS B 5205 / KS B 5202 (外部千分尺) 或精度等级相同的仪表。

**Size**: Need to use JIS B 7503 / KS B 5206 (Micrometer), JIS B 7507 / KS B 5203-2(Vernier caliper) JIS B 7502 / KS B 5205 / KS B 5202(External micrometer) or other same precision grade devices.

❖ **直流电压表**：必须使用0.2级的JIS C 1102 / KS C 1303-2 (电动指示仪) 度相同或更高等级的仪表，其输入电阻超过 $10\text{M}\Omega$ 。

**DC Voltmeter**: Need to use 0.2 grade type JIS C 1102 / KS C 1303-2(Electric Indicator) or much high precision devices, its internal resistance should over  $10\text{M}\Omega$

❖ **直流电流表和交流电流表**：必须使用0.2级的JIS C 1102 / KS C 1303-2 (电动指示仪) 度相同或更高等级的仪表，其输入电阻超过 $10\text{M}\Omega$ 。



**DC Ammeter and AC Voltmeter:** Need to use 0.2 grade type JIS C 1102 / KS C 1303-2(Electric Indicator) or much high precision devices.

### 7.3 容量测试 Test for Capacitance

依据图1所示, 设定充电电压(E)后(参照表1), 将SW开关转向1处进行充电, 根据表1中充电时间(T)与充电电压(V)的要求, 借助保护电阻(R)进行充电。当达到规定充电时间后, 将开关SW转向2, 按照表1中的放电电流(I)进行恒流放电, 记录产品从起始电压(V<sub>1</sub>)至结束电压V<sub>2</sub>过程所用时间(T<sub>d</sub>=T<sub>2</sub>-T<sub>1</sub>), 依据下述公式计算产品容量(C):

According to Fig. 1, setting the charging voltage (E, Based Table 1), put the switch SW to 1 for charging. And based on the Charging Time (T) and Charging Voltage (V)' s requirements, charge the cell by using Protection Resistance (R). Once reached the Charging Time, switch the SW to position 2, meantime, galvanostatic discharge the cell to the target voltage with the discharge current (Table 1). Record the time between the starting voltage V<sub>1</sub> and the ending voltage V<sub>2</sub> (T<sub>d</sub>=T<sub>2</sub>-T<sub>1</sub>), finally, Calculating the Capacitance (C) by the following formula:

$$C = \frac{I \times (T_2 - T_1)}{V_1 - V_2}$$

其中, C为测试样品的容量(F), E为直流恒压电源(V), R为保护电阻(Ω), V为直流电压表, I为恒流负载装置, A为直流电流表

Specifically, C was the cell' s capacitance(F), E named the DC constant power (V), R was the protection resistance(Ω), V was the DC Voltmeter, I was the constant current load, A was the DC ammeter.



图1 容量测试电路图

Fig. 1 Circuit Diagrams for Capacitance Test

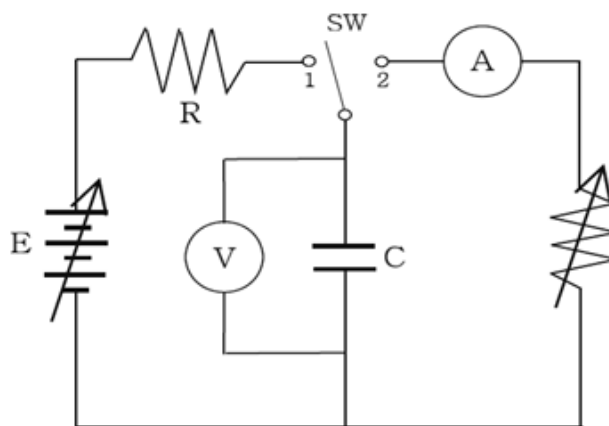

图2 样品的充放电曲线

Fig2. Charge/Discharge curves for Sample

表 1 容量测试过程的参数设定要求

Table1 Demands for Capacitance' s Test

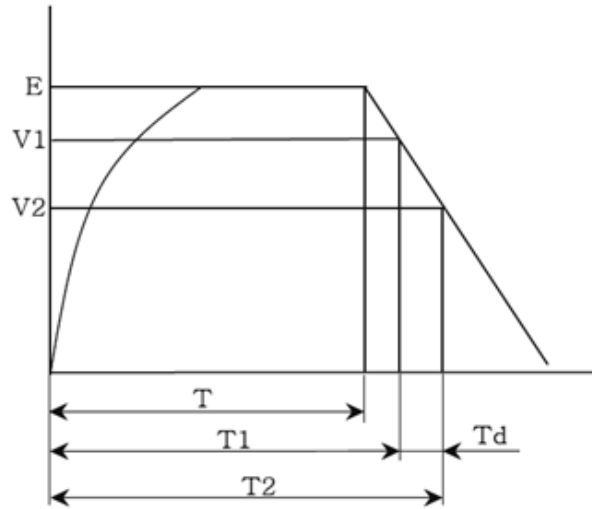
型号	充电电压 (E)	保护电阻 (R)	充电时间 (T)	放电电流 (I)	起始电压 (V <sub>1</sub> )	结束电压 (V <sub>2</sub> )
LIC 1340 H 4R2 C550	4.2V	10Ω	1 hours	280mA	4.2V	2.5V

#### 7.4 交流内阻测试 Test for AC Resistance

常温下，将单体充电至3.6V并恒压充电30min后，在1kHz条件下，采用交流阻抗仪进行交流内阻测试。

Charge the cell to 3.6V and keep this voltage for 30min, then using the AC Internal resistance to test its AC Resistance at 1kHz.

#### 7.5 高低温性能测试 Test for Low-high Temperature

25±2°C条件下，将单体参照《7.3 容量测试》方式充电至4.2V后，紧接着将其转移至设定温度(设定温度分别为-40±2°C，25±2°C，65±2°C)条件下，在4.2V持续稳压的同时将样品放置1h。此后，将产品按照表2中放电电流要求在设定温度条件下进行容量测试。

Based on the 《7.3 Test for Capacitance》 charging the cell to 4.2V at 25±2°C, and

move the cell to a fixed temperature ( $-40\pm 2^{\circ}\text{C}$ ,  $25\pm 2^{\circ}\text{C}$ ,  $65\pm 2^{\circ}\text{C}$ ), meantime charge the cell by constant voltage for 1h. After this, the cell's capacitance was tested at Table 2's current.

### **7.6 高温高湿存储特性 High temperature and high humidity storage properties**

常温条件下，将单体在表2电流条件下充电至3.6V并恒压充电1h，后将其放置在 $60\pm 2^{\circ}\text{C}$ 、 $90\pm 2\%$  RH的条件下存储1000h。接着将其冷却至室温，并参照《7.3 容量测试》和《7.4 交流内阻测试》方法测试样品的电化学特性。

Charge the cell to 3.6V at Table 2's current, and the charge 1h at constant voltage condition at room temperature. After this, put the cell to  $60\pm 2^{\circ}\text{C}$ 、 $90\pm 2\%$  RH conditions to storage 1000h. Finally, cooling the cell at room temperature and check its electrochemical properties by 《7.3 Test for Capacitance》 and 《7.4 Test for AC Resistance》.

### **7.7 充/放电循环性能测试 Charge/discharge cycling properties**

常温条件下，以5C电流值将单体充电至4.2V，紧接着将其以该电流放电至2.5V循环8000次后，参照《7.3 容量测试》和《7.4 交流内阻测试》要求测量其电化学特性。

Charge the cell to 4.2V at room temperature by 5 C-rate, and the discharge it to 2.5V at the same current. Once cycling 8000 times, re-checking its electrochemical properties by 《7.3 Test for Capacitance》 and 《7.4 Test for AC Resistance》.

## **8 注意事项 Notice**

### **8.1 使用 During Operation**

- ❖ 锂离子电容器的使用温度不宜超过额定温度上限或下限。

Working temperature of LIC should not exceed the upper and lower limits of the rated temperature.

- ❖ 锂离子电容器应在额定电压区间下使用。

LIC should be used at rated voltage.

- ❖ 锂离子电容器在使用之前请确认极性，禁止反接。

Check the polarity of LIC before power on. No reverse connecting.

- ❖ 外界环境温度对锂离子电容器的寿命具有重要影响，请远离热源。

Keep LIC away from heat. The temperature has a big influence on the working life of LIC.

- ❖ 锂离子电容器请勿直接接触水、油、酸或碱。  
No direct contacting with water, oil, acid or alkaline.
- ❖ 请勿挤压、钉刺或拆解锂离子电容器。  
No crushing, nail penetrating or disassembling LIC.
- ❖ 请勿随意丢弃锂离子电容器，废弃时请根据国家环保标准进行处理。  
No discarding. Dispose LIC based on the State Environmental-protection Standard.
- ❖ 本产品发货前已具有一定电压值，使用过程中切勿使正负极端子短路，常见产品短路情况如下表所示。  
The cell embraced constant voltage before shipment, therefore, the short circuit should be extremely forbidden. Familiar short circuit is shown in the following table 2.

表 2 常见的使用过程中产品短路情形

Table 2 Familiar short circuit situation

<p style="text-align: center;">测量中发生短路</p> <p style="text-align: center;">Short Circuit during Testing</p>	<p style="text-align: center;">产品处理中发生短路</p> <p style="text-align: center;">Short Circuit during connecting</p>
	
<p style="text-align: center;">产品放置在一起导致引线接触</p> <p style="text-align: center;">Radial connecting during the storage or</p>	<p style="text-align: center;">发生短路</p> <p style="text-align: center;">Short circuit</p>

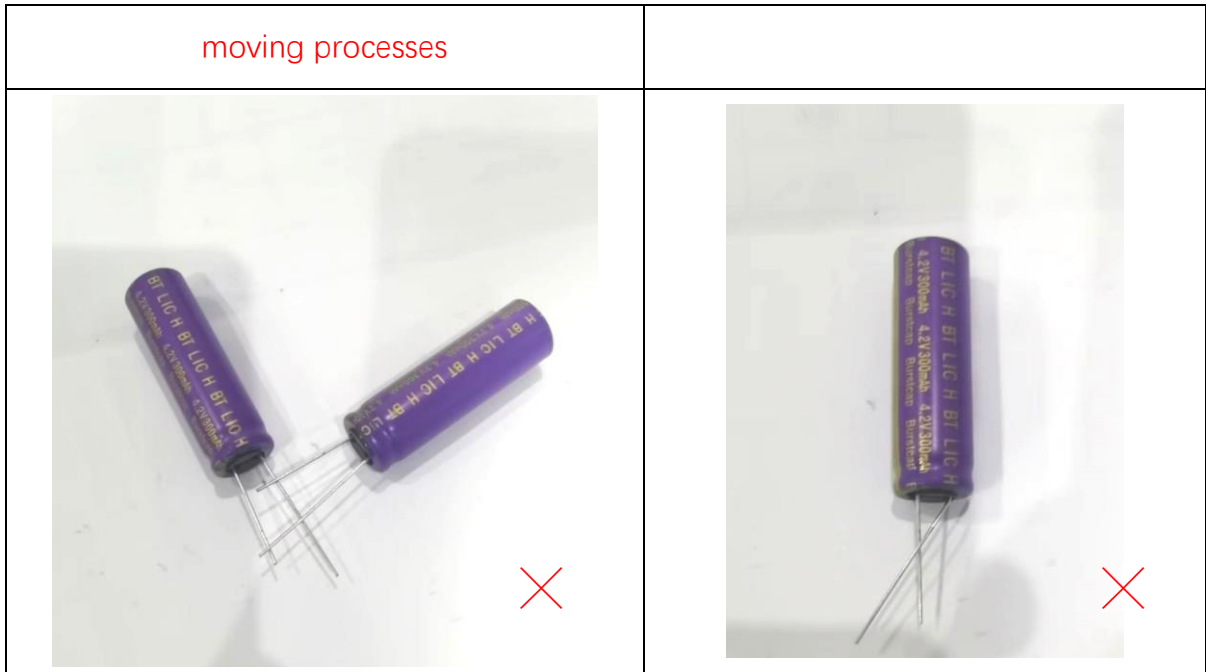

## 8.2 储存 Storage

- ❖ 锂离子电容器不可处于相对湿度为85%以上或含有有毒气体的场所，该种环境下引线及壳体易受潮及腐蚀，导致锂离子电容器断路。

No storage in a condition with a relative humidity exceeding 85% or with toxic gases. It is easy to cause the damage and corrosion of the terminals and case, resulting in disconnection.

- ❖ 锂离子电容器若需长期储存，请在温度10~55℃，相对湿度60%以下，通风良好的场所存放，严禁暴晒。

For Long-term storage, place LIC in a well-ventilated condition at 10 to 55℃, with a relative humidity below 60%. Forbidden to sun directly.

### 8.3 包装 Packaging

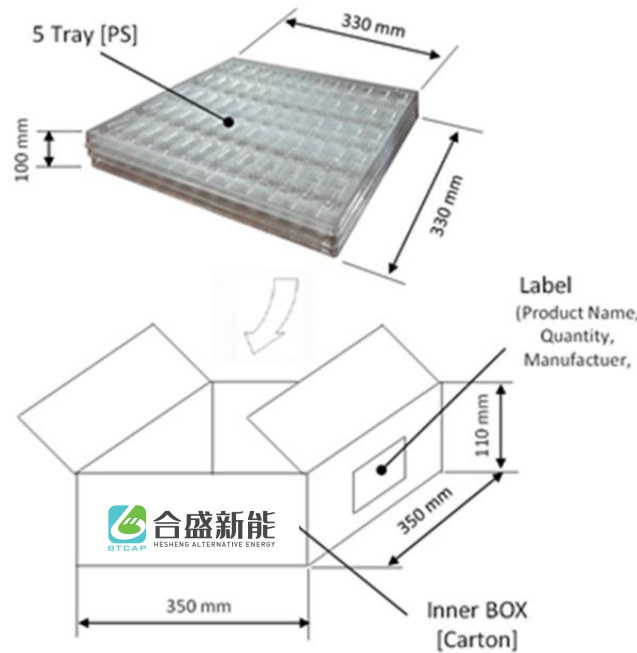

型号系列 Series	数量(个)Numbers			尺寸(Size) (W × L × H, mm)	重量(Mass) (Kg)
	托盘 Tray	内盒/分区 District	外箱 Box		
LIC 1340 H 4R2 C550	60	300	1200	710 x 710 x 230	9.0

如有任何关于BTcap锂离子电容的问题，请与我们联系。

If you have any questions about the BTcap LIC, please contact us.