

Specification

Customer		Name	Flow Switch	Type	MR-B678-1
----------	--	------	-------------	------	-----------

Unit: mm DIM Tolerance: ±0.3

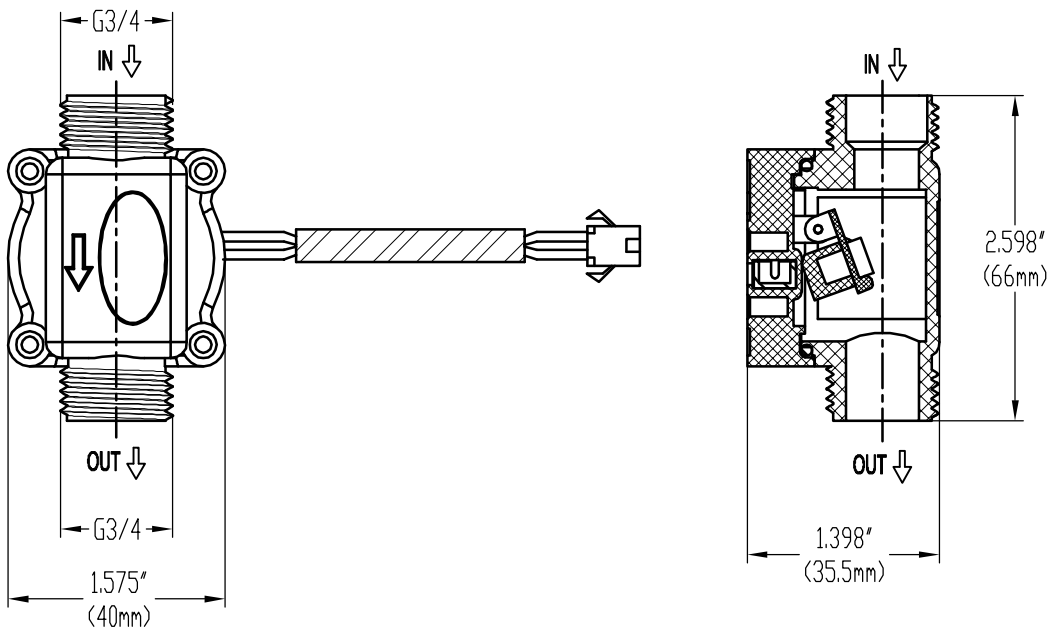

Electrical Characteristic			Technical Characteristic		
1	Contact form	NO (Normally Open)	1	Start-up Volume (min) :	≥1.5L/min
2	Max Contact Rating	10 W	2	Operate Volume (max) :	30L/min
3	Max Switch Voltage	100V	3	Standard Operate Pressure:	0.1~0.6MPa
4	Max Switch Current	0.5 A	4	Suffering Pressure:	1.2MPa
5	Max Contact Resistance	100mΩ	5	Operate Temperature:	-10~+80℃
6	Min Insulation Resistance	10 ¹⁰ Ω	6	Mounting Position:	Horizontal
7	Electrical Life	1X10 ⁷ (5Vdc,10mA)	7	Body Material:	PA+GF

Ningbo Holleywin Export&Import Trade Co., LTD.	APP	CHK	DSG	Remark	Scale	Page
				RoHS	1:1	1/1