

Specification

| | | | | | |
|-----------------|--|-------------|------------------------------------|-------------|-----------|
| Customer | | Name | The dishwasher distributor sensors | Type | MR-DCD-01 |
|-----------------|--|-------------|------------------------------------|-------------|-----------|

Unit: mm DIM Tolerance: ±0.2

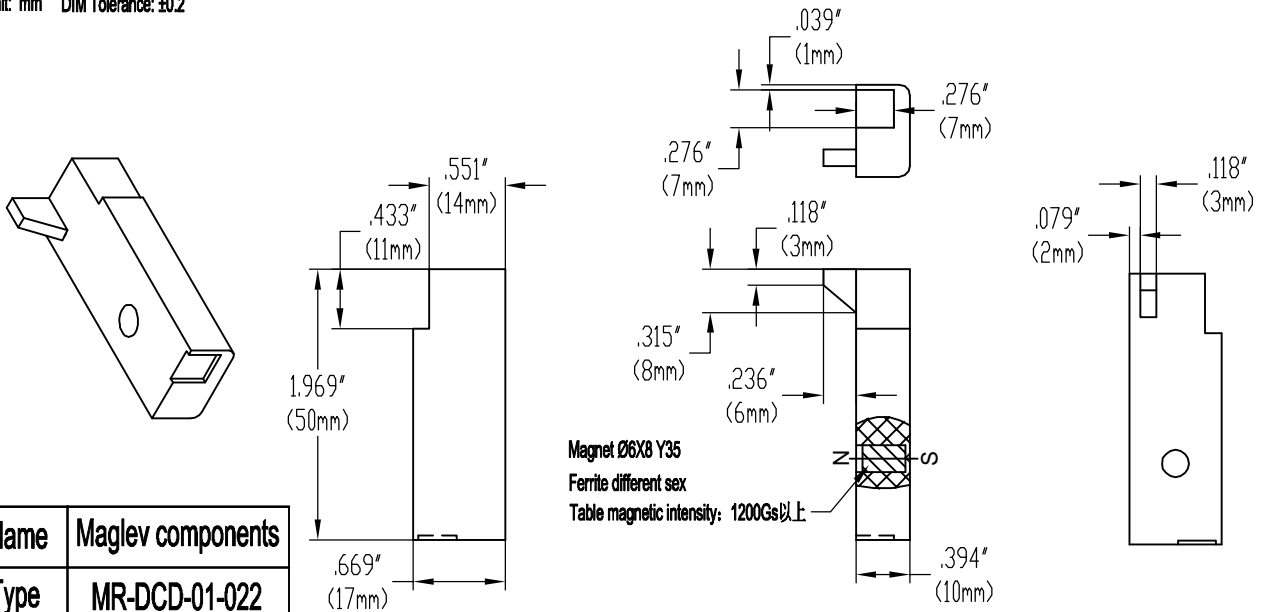

| | |
|-------------|-------------------|
| Name | Maglev components |
| Type | MR-DCD-01-022 |

Unit: mm DIM Tolerance: ±0.3

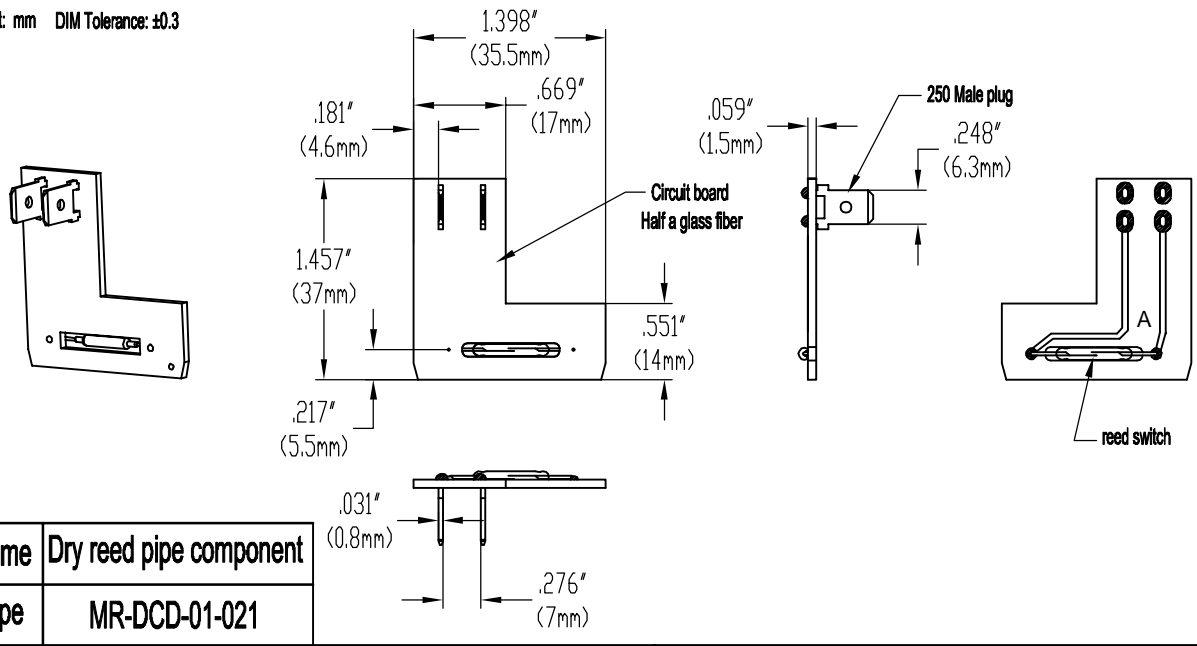

| | |
|-------------|-------------------------|
| Name | Dry reed pipe component |
| Type | MR-DCD-01-021 |

| Electrical Characteristic | | | Technical Characteristic | | |
|---------------------------|---------------------------|-------------------------------|--------------------------|---------------|--------------|
| 1 | Contact form | NO (Normally Open) | 1 | Min Shock | 30G |
| 2 | Max Contact Rating | 10 W | 2 | Min Vibration | 30G(10~50Hz) |
| 3 | Max Switch Voltage | 100V | 3 | Temp.Rating | -10~+60°C |
| 4 | Max Switch Current | 0.5A | 4 | Heat Shock | -20~+70°C |
| 5 | Max Contact Resistance | 100mΩ | 5 | | |
| 6 | Min Insulation Resistance | 10 ¹⁰ Ω | 6 | | |
| 7 | Electrical Life | 1X10 ⁷ (5Vdc,10mA) | 7 | | |

| | | | | | | |
|---|-----|-----|-----|-------------|-------|------|
| Ningbo Holleywin Export&Import Trade Co., LTD. | APP | CHK | DSG | Remark | Scale | Page |
| | | | | RoHS | 1:1 | 1/1 |