

Specification

Customer		Name	The dishwasher distributor sensors	Type	MR-DCS-01
-----------------	--	-------------	------------------------------------	-------------	-----------

Unit: mm DIM Tolerance: ±0.2

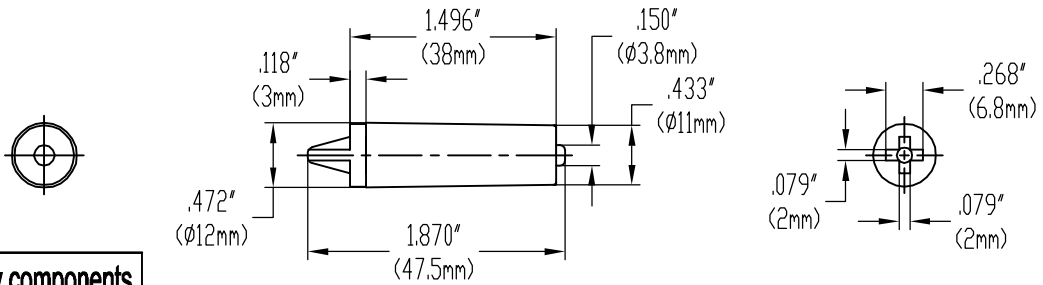
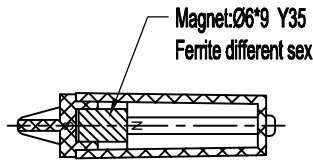

Name	Maglev components
Type	MR-DCS-01-022

Unit: mm DIM Tolerance: ±0.3

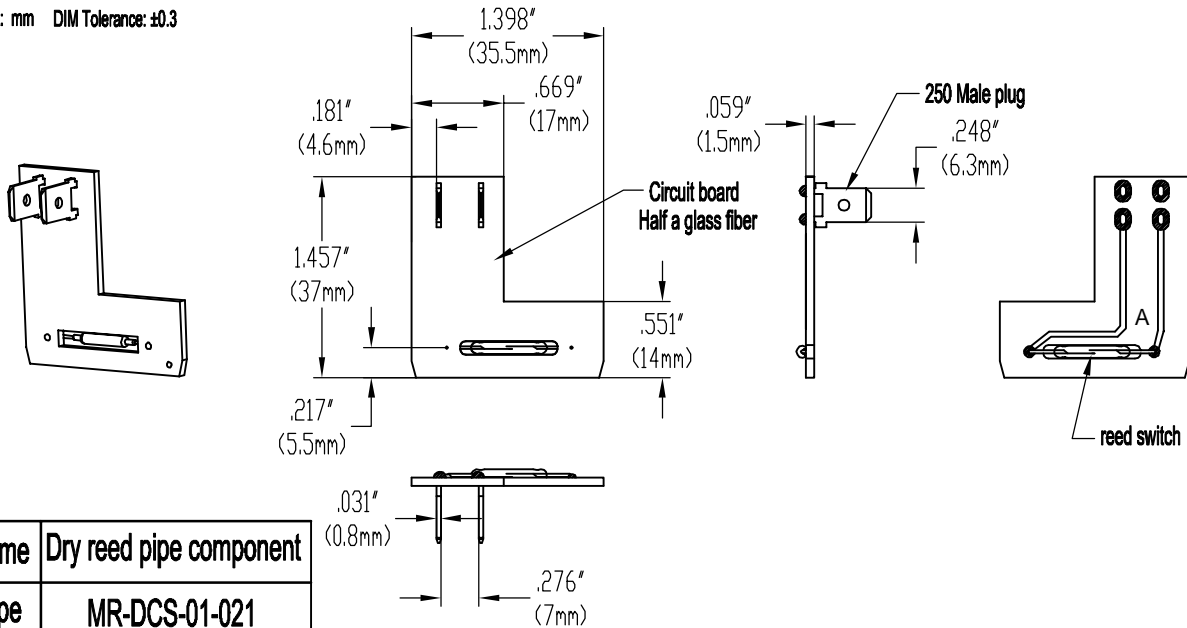

Name	Dry reed pipe component
Type	MR-DCS-01-021

Electrical Characteristic			Technical Characteristic		
1	Contact form	NO (Normally Open)	1	Min Shock	30G
2	Max Contact Rating	10 W	2	Min Vibration	30G(10~50Hz)
3	Max Switch Voltage	100V	3	Temp.Rating	-10~+60°C
4	Max Switch Current	0.5A	4	Heat Shock	-20~+70°C
5	Max Contact Resistance	100mΩ	5		
6	Min Insulation Resistance	10 ¹⁰ Ω	6		
7	Electrical Life	1X10 ⁷ (5Vdc,10mA)	7		

Ningbo Holleywin Export&Import Trade Co., LTD.		APP	CHK	DSG	Remark	Scale	Page
					RoHS	1:1	1/1