

# Specification

<b>Customer</b>		<b>Name</b>	Plastic level sensors	<b>Type</b>	MR0825-PP-1A1A
-----------------	--	-------------	-----------------------	-------------	----------------

## Movement explanation

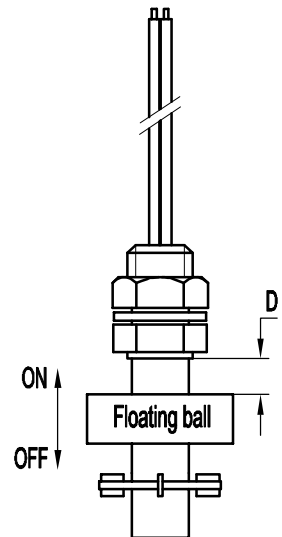
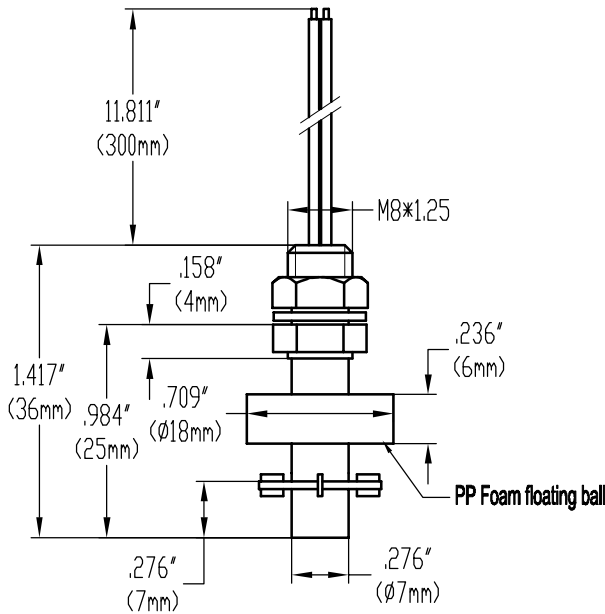

**Movement explanation :**  
 When the float up to the D position in the position between  $D=3\pm 1\text{mm}$ , the reed switches will be closed

Material Specification			Electrical Specification			Physics Specification		
Part name	Specification	Quantity	1.contact form	A(N.O.)	1.float pressure	$\leq 0.2\text{MPa}$		
1.float ball	PP	1PC	2.contact rating	10W	2.min resistance to vibration value	(11-1000HZ)		
2.float body	POM	1PC	3.max switching current	DC100/AC100	3.applicable temperature	$-10 \sim +85^{\circ}\text{c}$		
3.cap nut	POM	1PC	4.breakdown voltage	150min				
4.o-ring	rubber	1PC	5.max switching voltage	DC0.5				
5.e-ring	POM	1PC	6.max carry current	1.0A				
6.wire	UL 1007 24# black	300mm	7.contact resistance	100max				
7.filling	epoxy glue	—	8.insulation resis tance	$10^4\text{min}$				
8.terminal	—	—	9.get an electric shock life	$10^7$				
9.housing	—	—	designed by:	checked by:	drawing by:	drawing date:	scale:	
10.reed switch	324	1PC						

**Ningbo Holleywin Export&Import Trade Co., LTD.**

filename:		
drawing no.	edition:	sheet: 1